

A-A

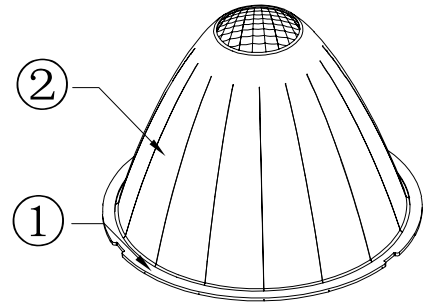

|                |               |
|----------------|---------------|
| Light Source   | LUMILEDS 1208 |
| PlasticHolder  | 92.70.411.00  |
| Metal Adaptor  |               |
| Design Angle   | 25°±3°        |
| Measured Angle | 25.6°         |
| Efficiency     |               |

光学装配示意图

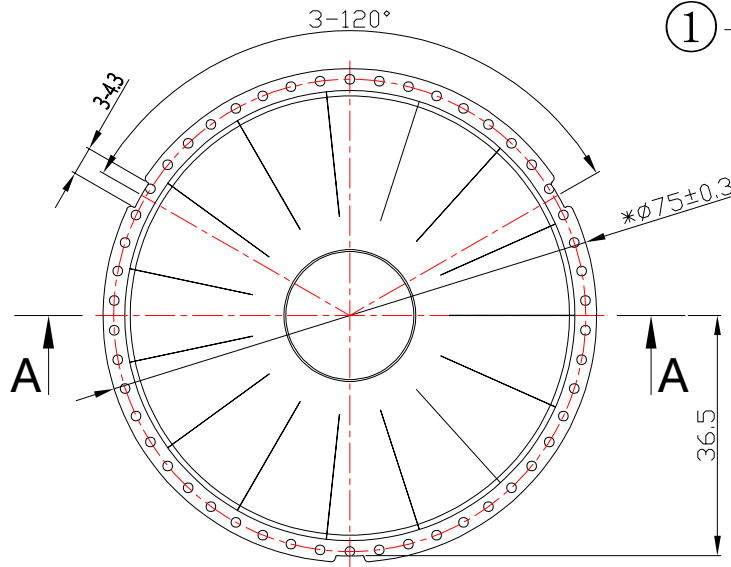
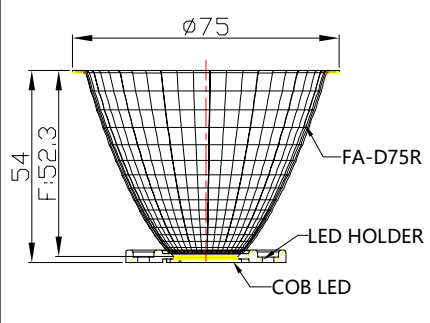

技术要求:

1. “\*”标记为重点控制尺寸。
2. 未注公差按尺寸公差表。
3. 产品外观按《N-SIP-QA-04 铝反光杯检验标准》。

| NO. | 品名                        | 产品代号           | 数量 | 材料/表面处理                |
|-----|---------------------------|----------------|----|------------------------|
| ①   | 内径68铝环<br>ø79H0.4-1060H24 | 97.77.403.01   | 1  | T=0.4mm 1060AL H24 /本色 |
| ②   | 2-2519-A                  | 94.02.2519.000 | 1  | T=0.4mm Miro 98AX4     |



|                   |                         |                       |                            |                     |
|-------------------|-------------------------|-----------------------|----------------------------|---------------------|
| 标记<br>MARK        | 处数<br>NO. OF MODIF.     | 更改内容<br>MODIFICATIONS | 签名<br>SIGNED BY            | 更改日期<br>MODIF. DATE |
| 设计<br>DESIGNER    | 制图<br>DRAWN BY          | 审核<br>CHECKED BY      | 比例<br>SCALE                | 1:1                 |
| 工艺<br>TECHNICAN   | 日期<br>DATE (DD-MM-YYYY) | 18-1-2025             | 视角<br>1st ANGLE PROJECTION |                     |
| 批准<br>APPROVED BY |                         |                       | 页数<br>PAGE                 | SHEET 1 OF 1        |

| DIMENSION TOLERANCE TABLE (UNLESS OTHERWISE STATED)           |         |          |           |           |           |           |
|---|---------|----------|-----------|-----------|-----------|-----------|
| 未注尺寸公差表   |         |          |           |           |           |           |
| > 0-5   | > 5-30  | > 30-90  | > 90-150  | > 150-250 | > 250-400 | > 400-700 |
| ±0.15   | ±0.2    | ±0.4     | ±0.5      | ±0.8      | ±1.5      | ±2        |
| ANGULAR DIMENSIONAL TOLERANCE TABLE (UNLESS OTHERWISE STATED) |         |          |           |           |           |           |
| 角度尺寸公差表 (单位: 度)   |         |          |           |           |           |           |
| > 0-10  | > 10-50 | > 50-120 | > 120-250 | > 250-360 |           |           |
| ±1°   | ±0.5°   | ±0.3°    | ±0.2°     | ±0.166°   |           |           |

|                          |                      |                |
|--------------------------|----------------------|----------------|
| <b>Nata</b> <sup>®</sup> |                      | 版本<br>VERSIONS |
|                          |                      | V1.0           |
| 产品编码<br>PRODUCT CODE     | 91.02.2882.001       |                |
| 产品名称<br>PRODUCT NAME     | 2-2882-L2            |                |
| 客户代号<br>CUSTOMER ID      | NT                   |                |
| 客户编号<br>CUSTOMER CODE    | FA-D75R-25D<br>切合反光罩 |                |

部件产品图  
COMPONENT PRODUCT DRAWING

单位  
UNIT  
mm