

Light Source	CITIZEN CLU038
Plastic Holder	92.70.412.00
Metal Adaptor	
Design Angle	36° ±3°
Measured Angle	37.3°
Efficiency	

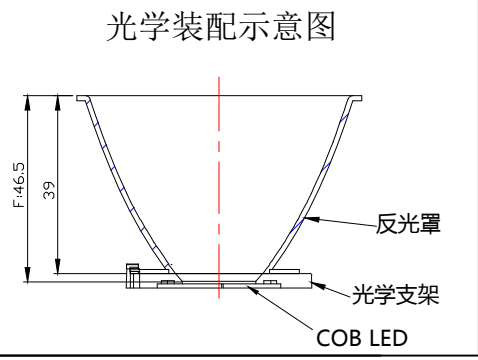

- 技术要求:
1. "*"标记为重点控制尺寸。
 2. 未注公差按尺寸公差表。
 3. 产品未注圆角与拔模斜度按3D。
 4. 产品外观按《N-SIP-QA-04 铝反光杯检验标准》。

NO.	品名	产品代号	数量	材料/表面处理
①	2-2541-H	94.02.2541.000	1	T=1.2mm 1090AL/高亮光
②	EW-G2-D75焊接片 (φ24)	97.77.274.03	1	T=1.0mm 1060AL H22

标记	处数	更改内容	签名	更改日期
MARK	NO.OF MODIF	MODIFICATIONS	SIGNED BY	MODIF. DATE
设计		制图	比例	1:1
工艺		审核	视角	1st ANGLE PROJECTION
批准		日期	页数	SHEET 1 OF 1
APPROVED BY		DATE(DD-MM-YYYY)	PAGE	

DIMENSION TOLERANCE TABLE (UNLESS OTHERWISE STATED) (UNIT:MM)							
> 0-5	> 5-30	> 30-90	> 90-150	150-250	250-400	400-700	
±0.15	±0.2	±0.4	±0.5	±0.8	±1.5	±2	

PUNCH TOLERANCE TABLE (UNLESS OTHERWISE STATED) (ANGLE)					
> 0-10	> 10-50	> 50-120	120-250	250-360	
±1°	±0.5°	±0.3°	±0.2°	±0.166°	

Nata [®]		版本 VERSIONS
K0		
产品编码 PRODUCT CODE	91.02.2684.000	
产品名称 PRODUCT NAME	2-2684-L	
客户代号 CUSTOMER ID	NT	
客户编号 CUSTOMER CODE	EW-G2-D69-36D 带缺口	

部件产品图
COMPONENT PRODUCT DRAWING

单位
UNIT
mm