

Product bill of material				
Serial number	material name	Masterial number	NO.	Describe
①	2-1845-A	94.02.1845.000	1	Material:T=1.0mm 1090AL
②	020283	97.76.283.00	1	Material:T=0.6mm SUS304

table for unmentioned tolerance in the drawing (unit: mm)			punch angle tolerance in the drawing (unit:degree)		
0-5	5-30	30-120	0-10	10-50	50-120
±0.15	±0.2	±0.5	±1°	±0.5°	±0.3°
120-250	250-400	400-700	120-250	250-360	360 above
±0.8	±1.5	±2	±0.2°	±0.166°	±0.083°

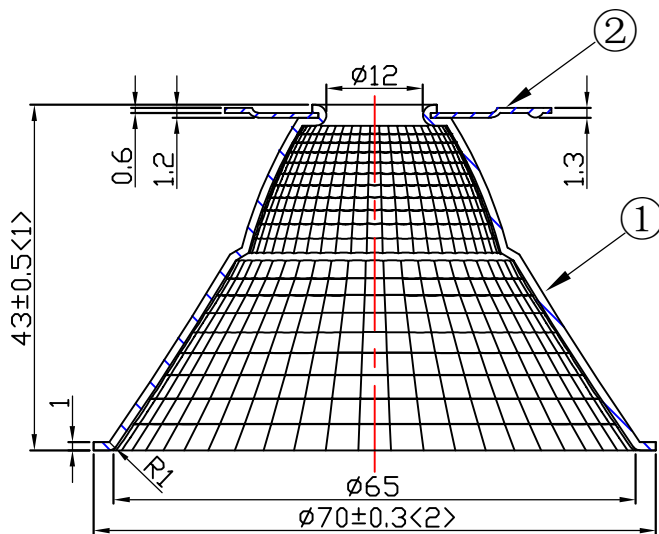

A - A

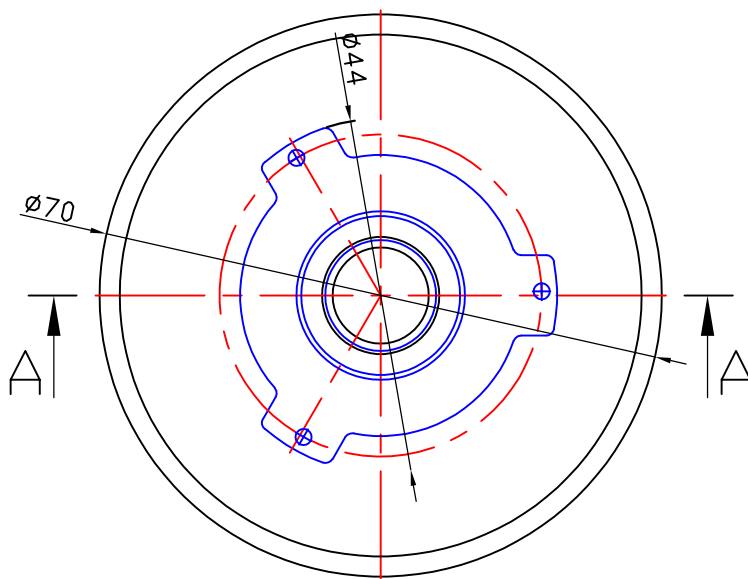

Light Source	XICATO XTM LES 9mm
PlasticHolder	
Metal Adaptar	
Design Angle	$40^\circ \pm 3^\circ$
Measured Angle	37.9°

Mark	Amended Times	Amended Content	Signature	Amended Date	<p>Nata[®] NATA Lighting Co.,Ltd</p> <p>Customer Item</p> <p>Customer Code</p> <p>Product Number</p> <p>Product Name</p>		
Control Version	A3	Design Version	K0	Client Version			
Designer		Drawing by		Proportion			1:1
Technology		Auditor		View			
Approval		Date	2018.01.04	Page			Total Page
						Customer Code	NT
						Product Name	2-1212-M