

| Product bill of material |               |                  |     |                         |
|--------------------------|---------------|------------------|-----|-------------------------|
| Serial number            | material name | Masterial number | NO. | Describe                |
| ①                        | 2-1847-A      | 94.02.1847.000   | 1   | Material:T=1.0mm 1090AL |
| ②                        | 020283        | 97.76.283.00     | 1   | Material:T=0.6mm SUS304 |

| table for unmentioned tolerance in the drawing (unit: mm) |         |         | punch angle tolerance in the drawing (unit:degree) |         |           |
|---|---------|---------|--|---------|-----------|
| 0-5   | 5-30    | 30-120  | 0-10   | 10-50   | 50-120    |
| ±0.15   | ±0.2    | ±0.5    | ±1°  | ±0.5°   | ±0.3°     |
| 120-250   | 250-400 | 400-700 | 120-250  | 250-360 | 360 above |
| ±0.8  | ±1.5    | ±2      | ±0.2°  | ±0.166° | ±0.083°   |

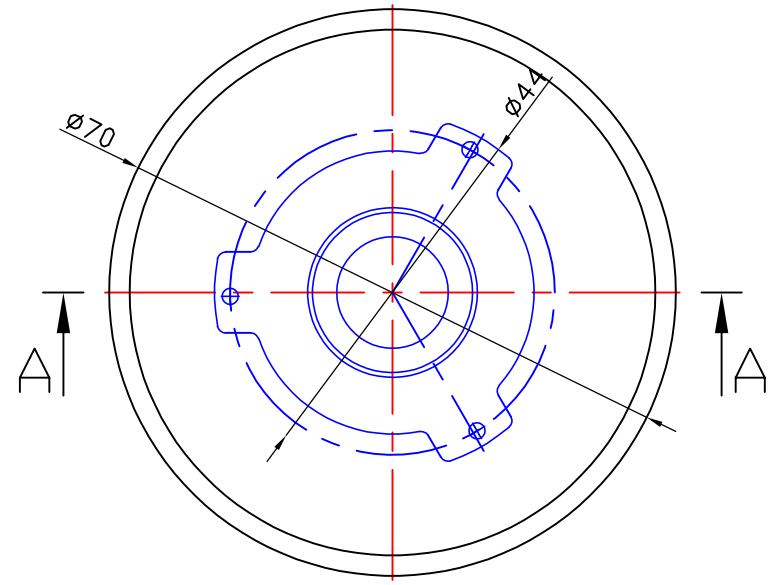
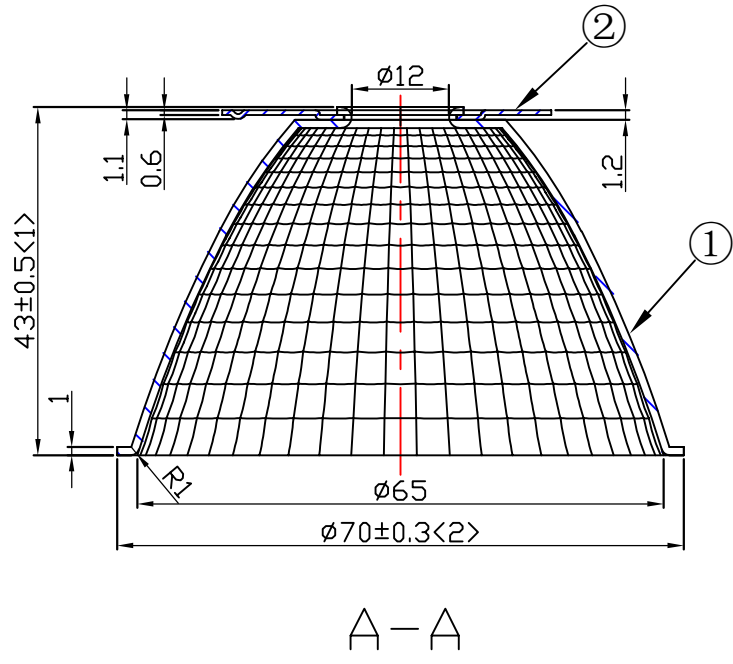

|                |                        |
|----------------|------------------------|
| Light Source   | XICATO<br>XTM LES 19mm |
| PlasticHolder  |                        |
| Metal Adaptor  |                        |
| Design Angle   | 24° ±3°                |
| Measured Angle | 23.8°                  |
| Efficiency     |                        |

|                  |               |                 |            |                |              |                                  |          |
|------------------|---------------|-----------------|------------|----------------|--------------|----------------------------------|----------|
|                  |               |                 |            |                |              | <br><b>NATA Lighting Co.,Ltd</b> |          |
|                  |               |                 |            |                |              |                                  |          |
| Mark             | Amended Times | Amended Content |            | Signature      | Amended Date | Customer Code                    | NT       |
| Controll Version | A1            | Design Version  | K0         | Client Version |              | Product Number                   |          |
| Designer         |               | Drawing by      |            | Proportion     | 1:1          | Product Name                     | 2-1163-M |
| Technology       |               | Auditor         |            | View           |              |                                  |          |
| Approval         |               | Date            | 2018.01.04 | Page           | Total_Page_  |                                  |          |