

Product bill of material				
Serial number	material name	Masterial number	NO.	Describe
①	2-1846-A	94.02.1846.000	1	Material:T=1.0mm 1090AL
②	020282	97.76.282.00	1	Material:T=0.6mm SUS304

table for unmentioned tolerance in the drawing (unit: mm)			punch angle tolerance in the drawing (unit:degree)		
0-5	5-30	30-120	0-10	10-50	50-120
±0.15	±0.2	±0.5	±1°	±0.5°	±0.3°
120-250	250-400	400-700	120-250	250-360	360 above
±0.8	±1.5	±2	±0.2°	±0.166°	±0.083°

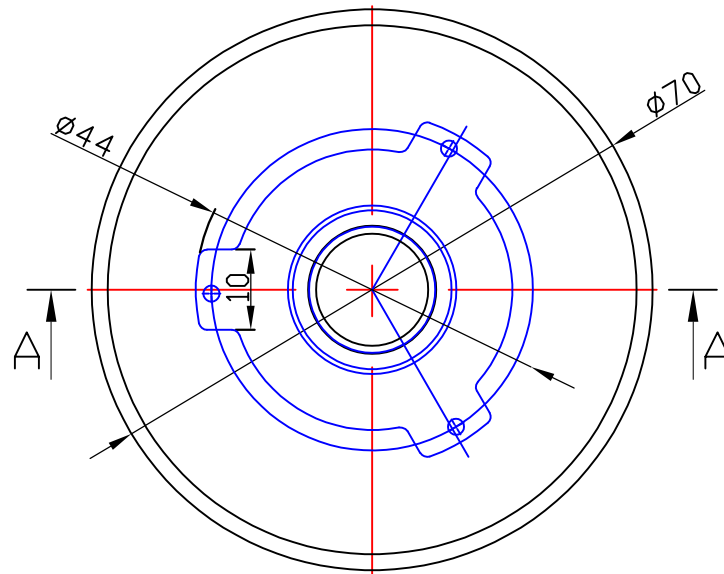
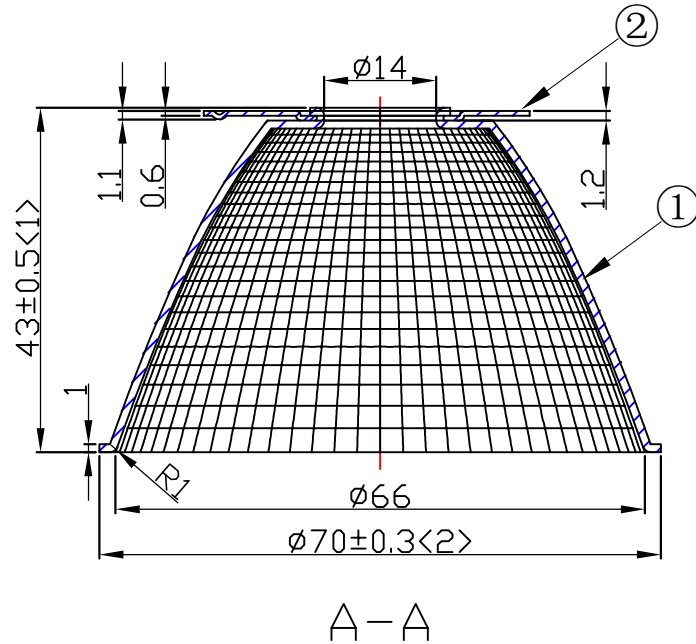

Light Source	XICATO XTM LES 9mm
PlasticHolder	
Metal Adaptor	
Design Angle	11° ±3°
Measured Angle	11.3°
Efficiency	

					 NATA Lighting Co.,Ltd		
							Customer Item
Mark	Amended Times	Amended Content		Signature	Amended Date	Customer Code	NT
Controll Version	A2	Design Version	K0	Client Version		Product Number	
Designer		Drawing by		Proportion	1:1	Product Name	2-1158-M
Technology		Auditor		View			
Approval		Date	2018.01.04	Page	Total Page		