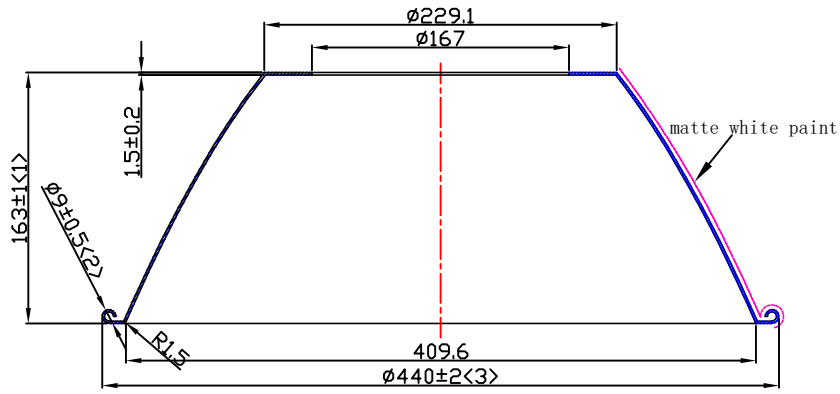
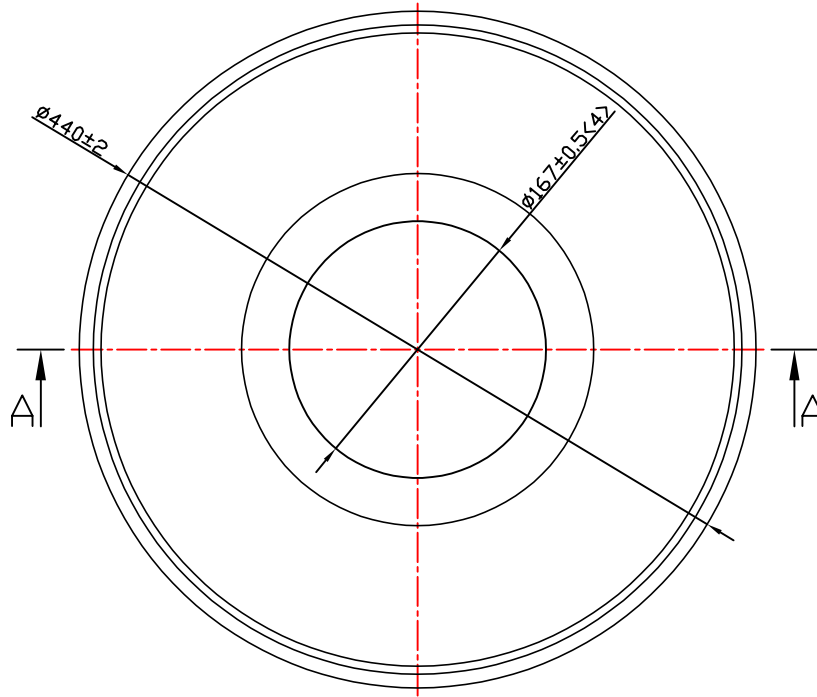

table for unmentioned tolerance in the drawing (unit: mm)			punch angle tolerance in the drawing (unit:degree)		
0-5	5-30	30-120	0-10	10-50	50-120
±0.15	±0.2	±0.5	±1°	±0.5°	±0.3°
120-250	250-400	400-700	120-250	250-360	360 above
±0.8	±1.5	±2	±0.2°	±0.166°	±0.083°

"< >" Marked for key control dimensions



A-A



Technical requirements:

1. Material: 1.5mm 1070AL.
2. Surface treatment: standard light+Outer surface with painting.
3. Product untolerance reference untolerance table.

					Engineering drawings				Nata [®] NATA Lighting Co.,Ltd		
Mark	Amended Times	Amended Content		Signature	Amended Date					Customer Item	0440工矿灯反射器
Controll Version	AO	Design Version	KO	Client Version						Customer Code	NT
Designer		Drawing by		Proportion	1:1					Product Number	91.17.0032.000
Technology		Auditor		View						Product Name	17-0032-K
Approval		Date	2021.11.05	Page	Total Page						