

Product bill of material				
Serial number	material name	Material number	NO.	Describe
①	1613-A	94.01.0613.000	1	Material:T=0.8mm 1090AL
②	020350	97.76.350.00	1	Material:T=0.6mm SUS304

table for unmentioned tolerance in the drawing (unit: mm)			punch angle tolerance in the drawing (unit:degree)		
0-5	5-30	30-120	0-10	10-50	50-120
±0.15	±0.2	±0.5	±1°	±0.5°	±0.3°
120-250	250-400	400-700	120-250	250-360	360 above
±0.8	±1.5	±2	±0.2°	±0.166°	±0.083°

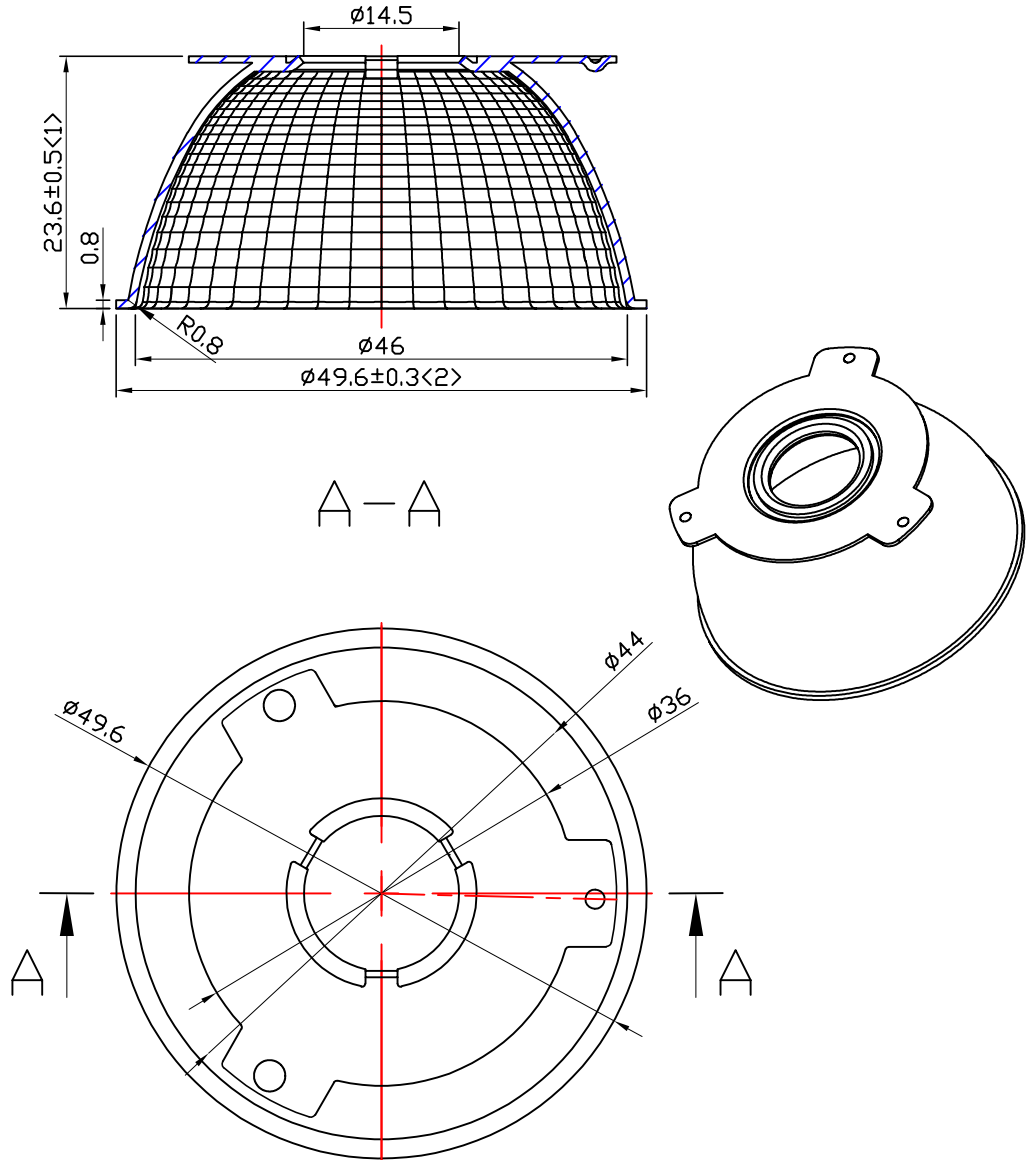

Light Source	XICATO XTM LES 9mm
Plastic Holder	
Metal Adaptor	
Design Angle	60° ±5°
Measured Angle	57.7°
Efficiency	

					Nata® NATA Lighting Co.,Ltd	
Mark	Amended Times	Amended Content		Signature	Amended Date	Customer Item
Controll Version	A3	Design Version	K0	Client Version		Customer Code
Designer		Drawing by		Proportion	1:1	Product Number
Technology		Auditor		View		Product Name
Approval		Date	2018.01.08	Page	Total Page	1612-M