

Product bill of material				
Serial number	material name	Masterial number	NO.	Describe
①	1769-A	94.01.0769.000	1	Material:T=0.8mm 1090AL
②	020282	97.76.282.00	1	Material:T=0.6mm SUS304

table for unmentioned tolerance in the drawing (unit: mm)			punch angle tolerance in the drawing (unit:degree)		
0-5	5-30	30-120	0-10	10-50	50-120
±0.15	±0.2	±0.5	±1°	±0.5°	±0.3°
120-250	250-400	400-700	120-250	250-360	360 above
±0.8	±1.5	±2	±0.2°	±0.166°	±0.083°

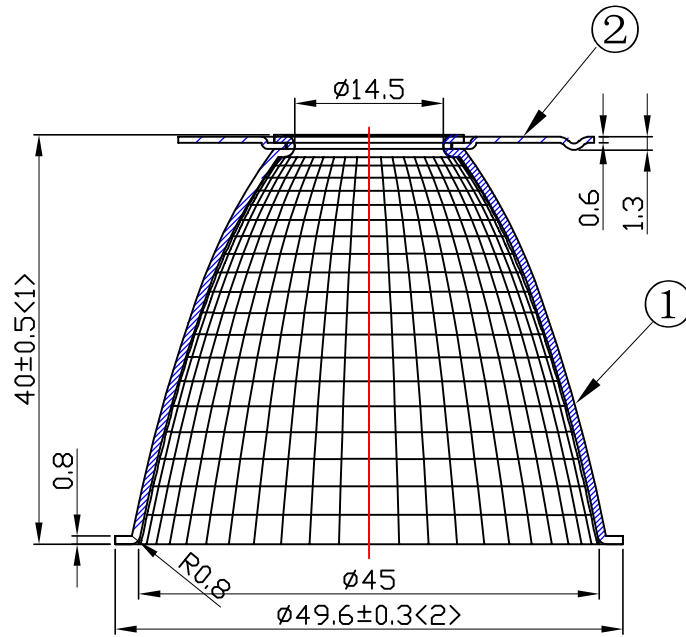

A-A

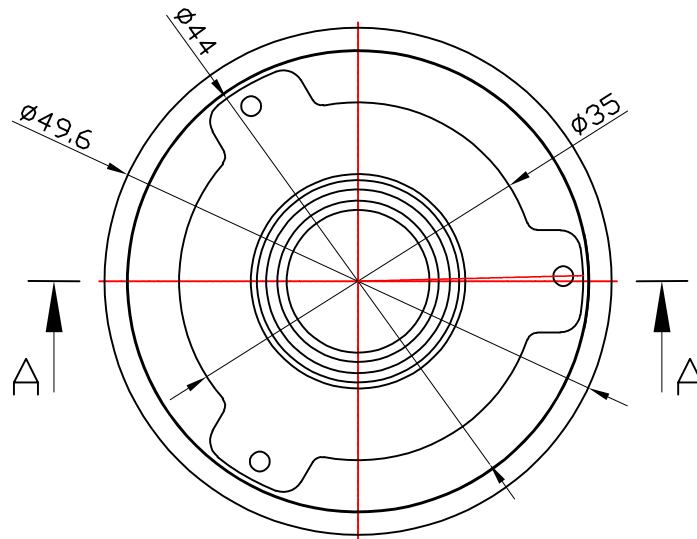

Light Source	XICATO XTM LES9mm
PlasticHolder	
Metal Adaptor	
Design Angle	$24^\circ \pm 3^\circ$
Measured Angle	$24.2^\circ$
Efficiency	

Mark	Amended Times	Amended Content	Signature	Amended Date	<p><b>Nata</b><sup>®</sup> <b>NATA Lighting Co.,Ltd</b></p> <p>Customer Item</p> <p>Customer Code</p> <p>Product Number</p> <p>Product Name</p>
Controll Version	A2	Design Version	K0	Client Version	
Designer		Drawing by		Proportion	
Technology		Auditor		View	
Approval		Date	2018.01.08	Page	
				Total Page	