

A - A

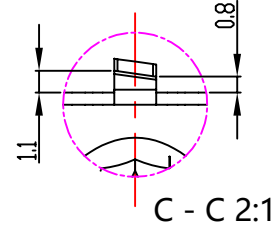

C - C 2:1

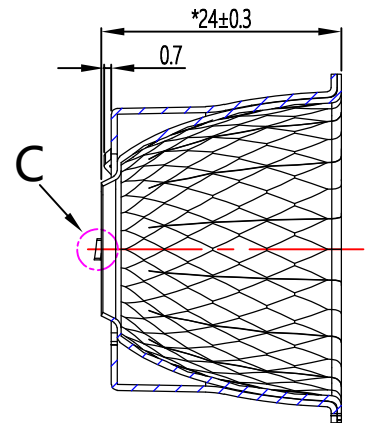
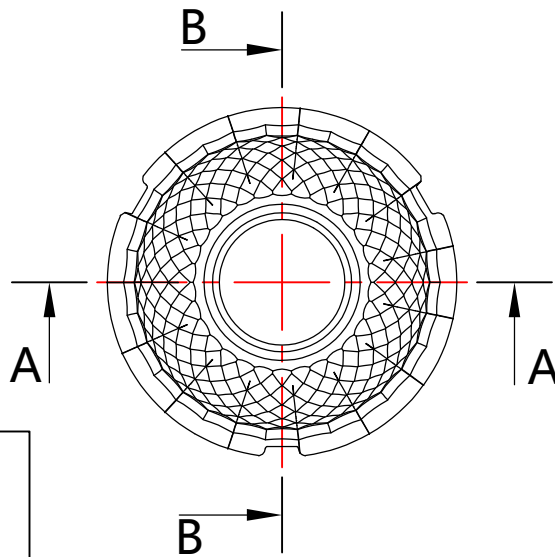

B - B

LIGHT SOURCE	LUMILEDS 1202HD
PLASTIC HOLDER	B1512-2-D25
METAL ADAPTAR	
DESIGNED B.A.	55°±5°
MEASURED B.A.	°
EFFICIENCY	

光学装配示意图

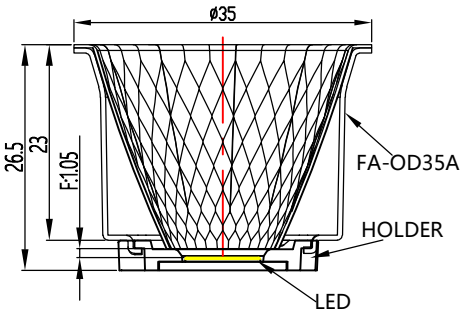

技术要求:
 1.产品未注圆角与拔模斜度按3D.
 2.产品质量控制按《切合反光罩检验标准》执行。

产品 BOM				
NO.	产品名称	产品编号	数量	材料/表面处理
①	1-1276-A2	94.01.1276.001	1	T=0.6mm 1060AL H22/ Andoizing
②	1-1277-A	94.01.1277.000	1	T=0.4mm High reflectivity aluminum(Mirror surface)

标记	处数	更改内容	签名	更改日期
MARK	NO.OF MODIF	MODIFICATIONS	SIGNED BY	MODIF. DATE
设计		制图	比例	1:1
DESIGNER		DRAWN BY	SCALE	
工艺		审核	视角	
TECHNICAN		CHECKED BY	1st ANGLE PROJECTION	
批准		日期	页数	
APPROVED BY		DATE(DD-MM-YYYY)	PAGE	
		04-07-2024		SHEET 1 OF 1

DIMENSION TOLERANCE TABLE (UNLESS OTHERWISE STATED)						
未注尺寸公差表						
> 0-5	> 5-30	> 30-90	> 90-150	> 150-250	> 250-400	> 400-700
±0.15	±0.2	±0.4	±0.5	±0.8	±1.5	±2
ANGULAR DIMENSIONAL TOLERANCE TABLE (UNLESS OTHERWISE STATED)						
角度尺寸公差表 (单位: 度)						
> 0-10	> 10-50	> 50-120	> 120-250	> 250-360		
±1°	±0.5°	±0.3°	±0.2°	±0.166°		

		版本	K-
		VERSIONS	
产品编码	91.01.1546.000	客户代号	NT
PRODUCT CODE		CUSTOMER ID	
产品名称	1-1546-L	客户编号	FA-OD35A-50D
PRODUCT NAME		CUSTOMER CODE	切合反光罩

部件产品图
 COMPONENT PRODUCT DRAWING

单位
 UNIT
 mm