

b面: 正面
表面磨砂面

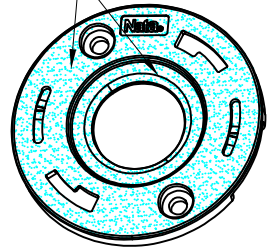

c面: 背面与侧壁
非可视面

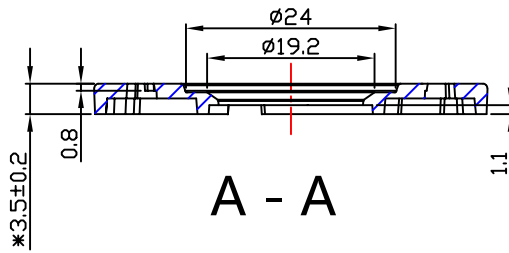
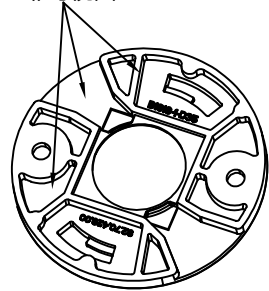

A - A

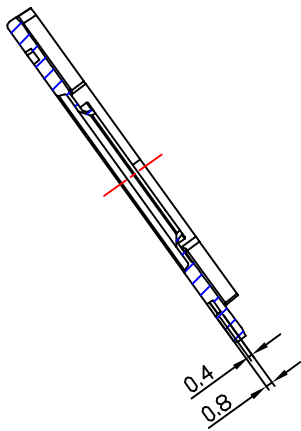

C - C

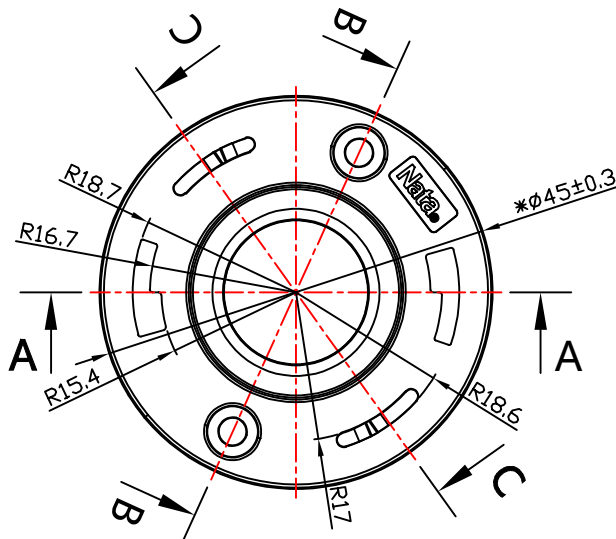

B - B

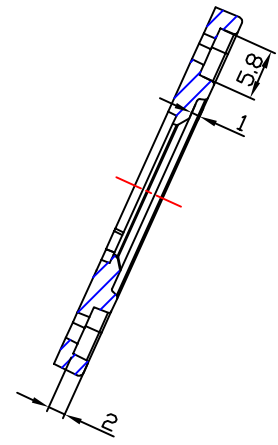

技术要求:

1. PC / 白色, 耐温105°.
2. 未注公差按GB/T14486-2008-MT6.
4. 产品未注圆角与拔模斜度按3D.
5. 表面无裂痕, 缺胶等不良.

| | | | | | | | |
|-------------------|---------------------|-------------------------|------------|----------------------------|--------------------------|-----------------|----------------|
| | | | | | Nata [®] | | 版本 VERSIONS |
| | | | | | | | K- |
| | | | | | 产品编码 PRODUCT CODE | 92.70.429.00 | |
| | | | | | 产品名称 PRODUCT NAME | B1818-1-D45焊线支架 | |
| | | | | | 客户代号 CUSTOMER ID | NT | |
| | | | | | 客户编号 CUSTOMER CODE | B1818-1-D45 | |
| 标记 MARK | 处数 NO. OF MODIF. | 更改内容 MODIFICATIONS | | 签名 SIGNED BY | 更改日期 MODIF. DATE | | |
| 设计 DESIGNER | | 制图 DRAWN BY | | 比例 SCALE | 1:1 | | |
| 工艺 TECHNICIAN | | 审核 CHECKED BY | | 视角 1st ANGLE PROJECTION | | | |
| 批准 APPROVED BY | | 日期 DATE (DD-MM-YYYY) | 11-04-2023 | 页数 PAGE | SHEET 1 OF 1 | | |
| | | | | | 产品图 PRODUCT DRAWING | 单位 UNIT | mm |