

b面:
正面, 表面磨砂面

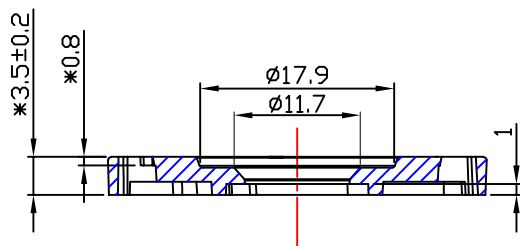

c面: 侧壁与背面。
非可视面。

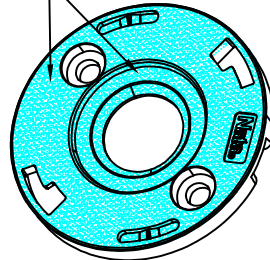
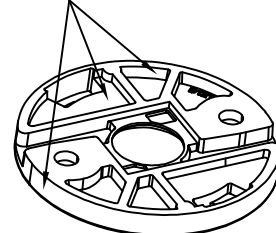

A - A

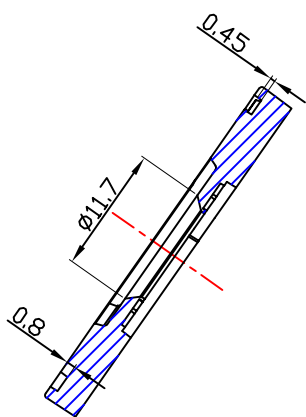

B - B

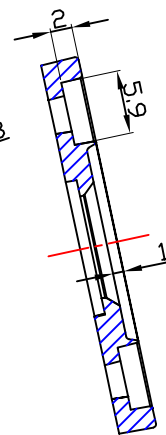
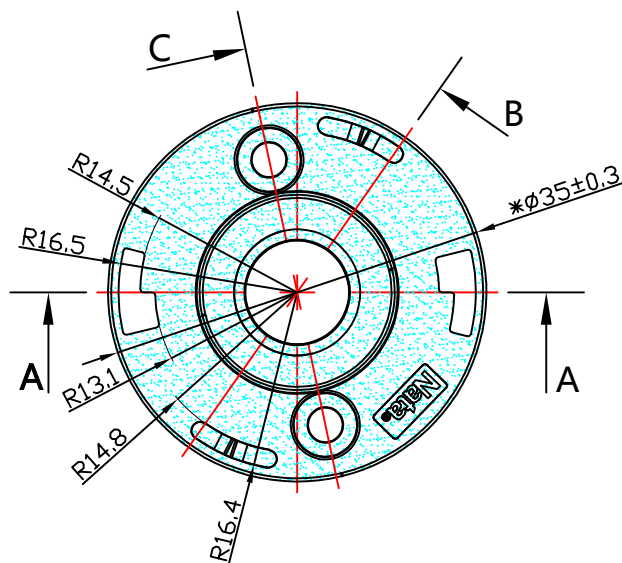

C - C

技术要求:

- 1.PC/ 白色, 耐高温105°。
- 2.未注公差按GB/T14486-2008-MT6。
- 3.产品未注圆角与拔模斜度按3D。
- 4.表面无裂痕, 缺胶等不良。

标记 MARK	处数 NO. OF MODIF.	更改内容 MODIFICATIONS	签名 SIGNED BY	更改日期 MODIF. DATE
设计 DESIGNER	制图 DRAWN BY	比例 SCALE	1:1	
工艺 TECHNICIAN	审核 CHECKED BY	视角 1st ANGLE PROJECTION		
批准 APPROVED BY	日期 DATE (DD-MM-YYYY)	12-04-2023	页数 PAGE	SHEET 1 OF 1

ENGINEERING DRAWING			
---------------------	--	--	--

		版本 VERSIONS	K-
		产品编号 PRODUCT CODE	92.70.426.00
产品名称 PRODUCT NAME		B1212-1-D35焊线支架	
客户代号 CUSTOMER ID		NT	
客户编号 CUSTOMER CODE		B1212-1-D35	